

■ PTL - peristaltic pumps



topflo®

PTL peristaltic pumps - low pressure

Suitable for pumping and dosing low or high viscous, pasty, pure, neutral, aggressive or abrasive liquids, those containing gases or which tend to froth or those containing solids in the following industries : paint, dairy and beverage, meat and fish processing, pharmaceutical and cosmetics, waste water and water treatment, chemical and petrochemical industries, pulp and paper, textile, soap and fats, building, ceramics.

Tapflo PTL pumps provide process confidence and offer cost savings through:

- Accurate and repeatable dosing and metering
- Long life and greater reliability
- Self-priming
- Continuous dry running
- Lowest cost of ownership
- Quick and easy maintenance



With experts advice to give the best system and installation

to deliver the promised results

SELF-PRIMING and DRY-RUNNING

It is not always possible to position a pump in the ideal location and often self-priming and dry- running performance is required. These conditions can cause wear in conventional pumps, resulting in loss of flow and premature failure. Tapflo pumps can self-prime up to 9.8 metres and run dry indefinitely.

LOWEST COST of ownership with quick and easy maintenance

Leakage, clogging or blockage of conventional positive displacement pumps which incorporate seals, valves, lobes, rotors or vanes can be a regular occurrence and expensive to rectify. Tapflo PTL pumps contain the fluid in a tube or hose, requiring only one component to be changed, which means that maintenance costs are considerably lower than other pump types. Increased plant productivity and lower repair costs means pump payback is over months rather than years.

ACCURATE and REPEATABLE dosing and metering

Industry requires repeatable pump control for accurate dosing. Many traditional positive displacement pumps deliver varying flow rates, resulting in scrapped product and increased costs. PTL pumps are accurate up to $\pm 0.5\%$ across their total speed range, with the additional benefit of process control capabilities which allows easy installation. Less waste means increased profits.

LONG LIFE and GREATER RELIABILITY

Pump failure cannot be tolerated. Tapflo pumps have no seals, valves, diaphragms, glands or immersed rotors to leak, clog or replace. Abrasive, corrosive and aggressive liquids are handled with ease because the fluid stays within the tube and never comes into contact with moving parts of the pump. The PTL range is designed and manufactured for heavy duty industrial use, and advanced elastomer technology ensures accurate and repeatable performance that truly outperforms other pumps.

Major improvements

Our customers have made major improvements in process performance, maintenance and product quality, resulting in cost savings previously thought unavailable.

■ Operating data

Capacity:	up to 10 m ³ /h
Viscosity:	up to 15000 cps(3)
Temperature of pumped liquid:	up to 135°C (1)
Differential pressure:	up to 4 bar (2)
Discharge pressure:	up to 4 bar
Achievable suction:	up to 0.6 bar (3)

1- At a room temperature of 20°C. Furthermore, it depends on the pumped fluid, on the hose quality and on the motor construction.

2- It depends on the pump dimension and on the hose quality.

3- It depends on the pump dimension/execution, on the speed and on the hose material.

PTL peristaltic pumps - low pressure

A proven design

Two rollers mounted at 180° on a rotor compress alternatively a thick-walled hose in a patented concentric guide and push the pumped liquid from the suction to the discharge side. Roller movement compresses the hose along the casing wall and creates constant vacuum at the suction side of the pump. In this way, liquids are conveyed within the hose and do not get in contact with any metal part.

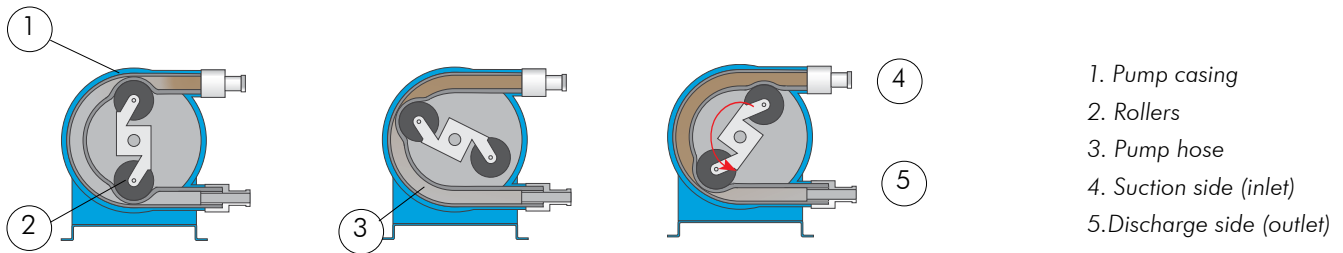

Tapflo pumps clearly outperform other pumps which rely on seals, valves or vanes for their operation. These components are repeatedly the cause of pump failure and high maintenance. No other positive displacement pump offers this unique separation of pump and fluid.

In sizes PTL 09–25, the rotor is supported by oversized ball bearings located within the pump casing; in sizes PTL 30–45

the rotor is supported by the heavy-duty bearings of the flanged drive unit.

The Tapflo PTL range provides flow rates from micro-litres per minute to 10 cubic metres per hour and pressures up to 5 bar. Fixed, variable, explosionproof, and air operated drives, with comprehensive control options to enable pumps to be configured to your requirements.

Tapflo PTL pump in your industry

Pharmaceutical industry

Challenge: it demand sterility and a high degree of precision to ensure the integrity and quality of the end product. Fluid isolation and precise metering are vital, and not meeting these demands can be enormously costly.

Pumped fluids: chemical dosing, liquid protein, vaccines, serum, plasma, syrups.

Water treatment

Challenge: reduce the down time due to maintenance of costly dosing pumps and elimination of expensive auxillary equipment.

Pumped fluids: sodium hypochlorite, ferric chloride, sodium bisulfite, fluoride, polymers, aqueous ammonia, potassium permanganate, caustic soda, and many more.

Shampoo manufacturers

Challenge: eliminate potential for foaming fluid on bottle filling lines.

Pumped fluids: shampoos

Tapflo pumps are exceptionally low shear, ensuring product quality, accurate and predictable performance with subsequent cost savings.

Pasta industry

Challenge: inspectors are concerned about contamination if the hose breaks. Our competition uses a food grade oil for hose lubrication, but within 1-2 days the hose begins to wear (turns black), requiring the customer to change hoses every 2 days.

Pumped fluids: egg white & yolk, edigible fat, semolina, natural flavoring.

Bread dough & fruit cake manufacturers

Challenge: require semi-accurate metering of viscous products containing solids.

Pumped fluids: water & salt mixtures, natural flavorings, fats, fruit cake dough/mixture (i.e. fruit cake has nuts and fruit pieces that need to stay whole).

Cheese manufacturers

Challenge: require a low shear pump so fibers in cheese aren't separated.

Pumped fluids: Cream, milk and yogurt.

Technical characteristics – hoses

more choices – more useful

Tapflo pump have selected the most comprehensive range of hoses to suit all the specific need of the industry.

■ Hose dimensions

SIZE	ID	OD	Length
	mm		
PTL 09	9	16	330
PTL 13	13	22	390
PTL 17	17	31	590
PTL 25	25	43	860
PTL 30	30	55	1150
PTL 45	45	75	1455



® Pharmed Reg. Saint-Gobain Performance Plastics

■ Available hose materials

Without reinforcing: Neoprene ; Hypalon ; Norprene® ; Silicone ; Pharmed®
 With polyamide reinforcing: Natural rubber (NR) ; NBR ; EPDM
 Other qualities on demand.

MATERIAL	Hose Identification	Operating Temperatures	Industry Approvals	Available
Neoprene	Flat black color, rough surface, rubber smell	0 to 60°C		PTL09 to PTL25
Norprene®	Off white, smooth surface	-35 to 135°C	USP Class VI FDA 21 CFR 177.2600 NSF listed (Standard 51)	PTL09 to PTL45
Silicone	Transparant, smooth surface or rust color	0 to 140°C	USP Class VI FDA 21 CFR177.2600	PTL09 to PTL25
Pharmed®	Cream color, Pharmed* name on hose	-30 to 135°C	USP Class VI FDA 21 CFR 177.2600 NSF listed (Standard 51)	PTL09 to PTL13
Hypalon	Black color, yellow stripe, double braided	0 to 90°C		PTL09 to PTL45
EPDM Rubber	Black color, white stripe, double braided	0 to 90°C		
Natural Rubber	Black color, green stripe, double braided	0 to 80°C		
Nitrile Rubber	Black color	0 to 80°C		

PTL peristaltic pumps - low pressure

Motorization

Gear motors or variable speed motors, both TEFC and explosion, electronic gear motor, inverters.
Upon request, pneumatic drive units are available.

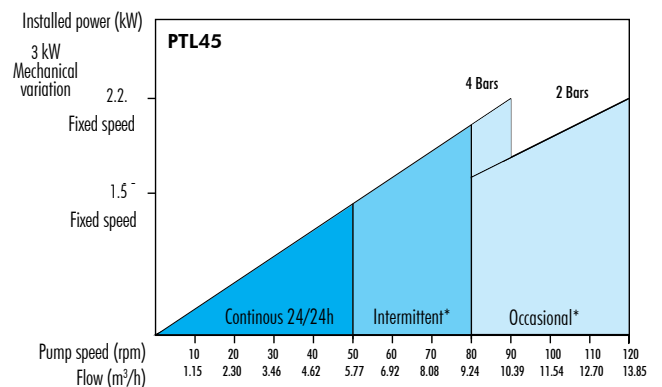
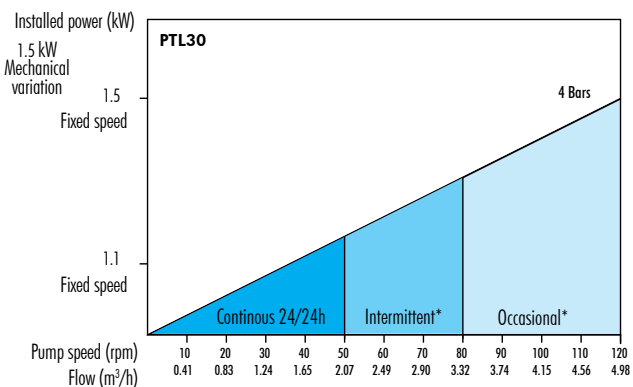
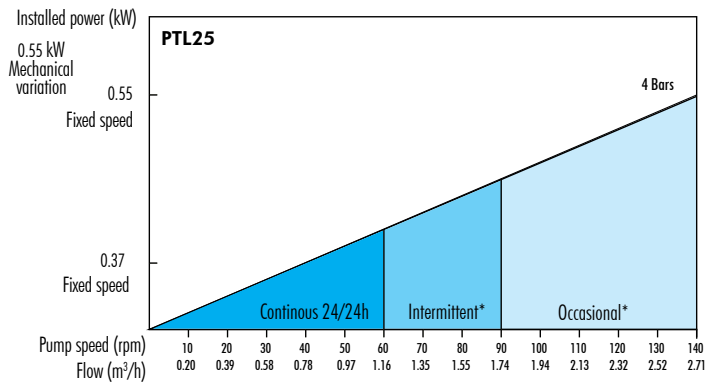
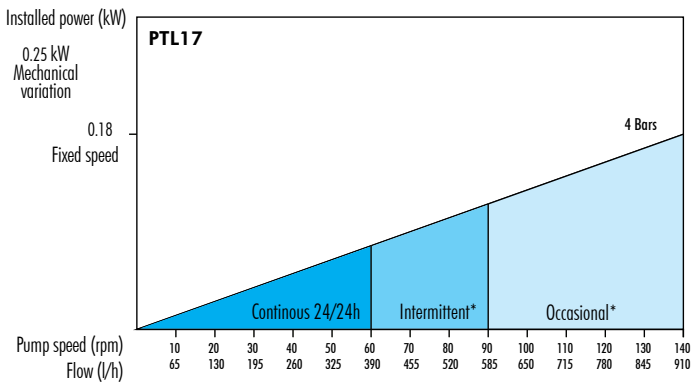
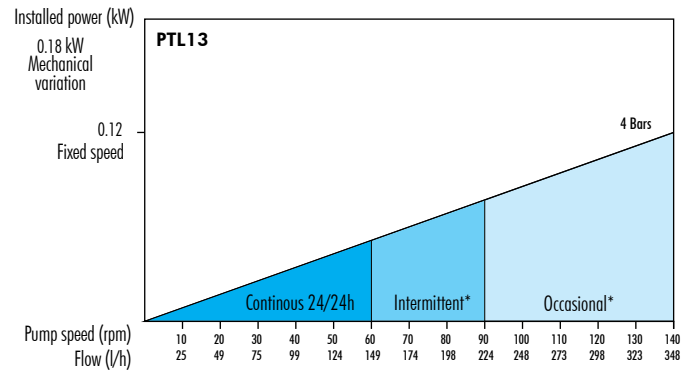
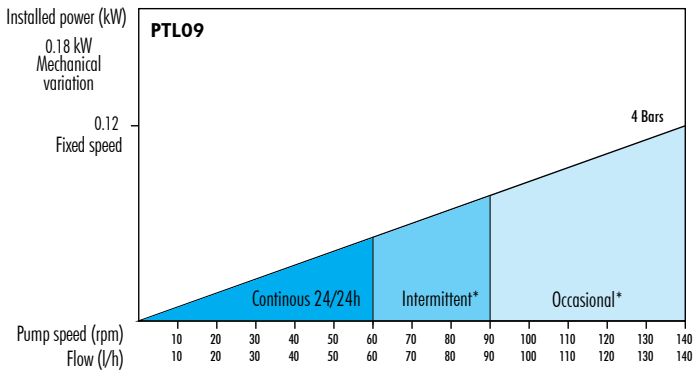

Construction

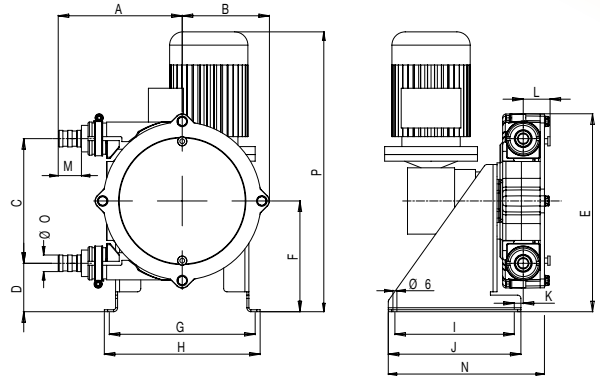

SIZE	A	B	C	D	E	F	G	H	I	J	K	L	M	N	O	P	ØQ
PTL 09F	114	75	104	58	185	110	145	160	156	170	3,5	25	20	187,5	15	335	6
PTL 09VM	114	75	104	58	185	110	145	160	156	170	3,5	25	20	187,5	15	485	6
PTL 13F	126	95	132	61	222	127	165	180	156	170	10	28	20	197	19	352	6
PTL 13VM	126	95	132	61	222	127	165	180	156	170	10	28	20	197	19	502	6
PTL 17F	187	131	188	73	290	167	220	235	180	200	13,5	40,5	35	235,5	25	427	6
PTL 17VM	187	131	188	73	290	167	220	235	180	200	13,5	40,5	35	235,5	25	527	6

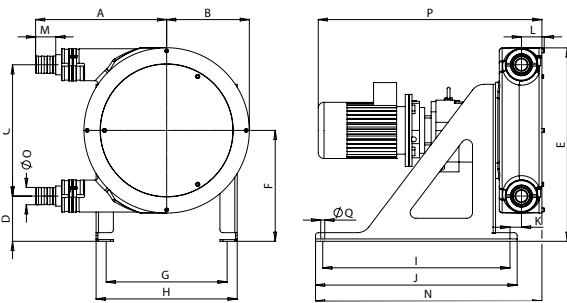

F = Fixed Speed Geared Motor Only
VM = Mechanical Variator & Geared Motor



SIZE	A	B	C	D	E	F	G	H	I	J	K	L	M	N	O	P	ØQ
PTL 25F	275	170	256	90	388	218	240	270	400	440	18	52,5	45	482	38	580	11
PTL 25VM	275	170	256	90	388	218	240	270	400	440	18	52,5	45	482	38	720	11
PTL 30F	345	226	364	148	556	330	330	380	550	600	22	66,5	55	655.5	45	672,5	14
PTL 30VM	345	226	364	148	556	330	330	380	550	600	22	66,5	55	655.5	45	812,5	14
PTL 45F	455	287	456	157	672	385	420	470	650	700	40	79	70	786	60	776,5	14
PTL 45VM	455	287	456	157	672	385	420	470	650	700	40	79	70	786	60	916,5	14

REF	DESCRIPTION	MATERIAL DESIGN
1	Pump casing	Aluminium alloy
2	Rotor	Aluminium alloy
3	Pressure rollers	Plastic/light alloy (1)
4	Pump hose	(2) See hose material chart page 4.

(1) According to pump size
(2) According to pumped liquid and to operating conditions

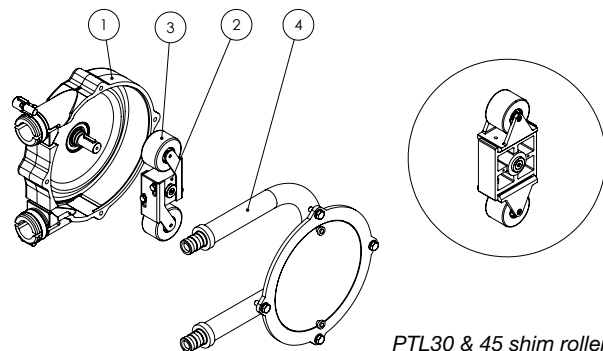

PTL30 & 45 shim roller adjustment.

Please contact us at your nearest Tapflo office

Tapflo has approximately 50 sales offices spread over more than 20 countries. In addition to this we are represented by independent distributors in about another 30 countries.

- Australia ■ Belarus ■ Belgium ■ Bosnia ■ Brazil ■ Bulgaria ■ Chile ■ China ■ Colombia ■ Croatia ■ Czech/Slovakia ■ Denmark
- Ecuador ■ Estonia ■ Finland ■ France ■ Greece ■ Germany ■ Hong-Kong ■ Hungary ■ India ■ Indonesia ■ Iran ■ Ireland
- Israel ■ Italy ■ Kazakhstan ■ Latvia ■ Lithuania ■ Macedonia ■ Malaysia ■ Montenegro ■ The Netherlands ■ New Zealand
- Norway ■ Poland ■ Philippines ■ Romania ■ Russia ■ Singapore ■ Slovenia ■ South Africa ■ Spain ■ Sweden ■ Switzerland
- Syria ■ Taiwan ■ Thailand ■ Turkey ■ Ukraine ■ United Arab Emirate ■ United Kingdom ■ USA

www.tapflo.com

Belarus

Tapflo Belarus
Tel: +375 17 3121370
sales@tapflo.by

Bulgaria

Tapflo EOOD
Tel: +359 (2) 974 18 54
sofia@tapflo.org

Czech & Slovakia

Tapflo s.r.o.
Tel: +420 548 138 660
tapflo@tapflopump.cz

China

Tapflo (Wuxi)
Tel: +86 510 8241 7602
sales@tapflo.cn

Denmark

Tapflo Danmark
Tel: +45 36 454600
info@tapflo.dk

France

Tapflo France
Tel: +33 1 34 78 82 40
info@tapflo.fr

India

Tapflo Pumps (India)
Tel: +91 44 26534479
tapfloindia@gmail.com

Ireland

Tapflo Ireland Ltd
Tel: +353 1 2011911
info@tapflo.ie

Italy

Tapflo Italia
Tel: +39 0362307698
info@tapfloitalia.com

Kazakhstan

Tapflo Kazakstan
Tel: +7 727 256 05 45
sales@tapflo.kz

Latvia

Tapflo Latvia
Tel: +371 67472205
riga@tapflo.lv

Poland

Tapflo Sp. z o.o.
Tel: +48 58 5301181
gda@tapflo.pl

Romania

S.C. Tapflo Rom. S.r.l.
Tel: +40 21 3451255
sales@tapflo.ro

Russia

Tapflo Company
Tel: +7 495 232 18 28
sales@tapflo.com.ru

Serbia

Tapflo d.o.o.
Tel: +381 21 44 58 08
sales@tapflo.rs

Spain

Tapflo Iberica
Tel: +34 677 47 89 25
avives@tapfloiberica.es

South Africa

Tapflo (Pty) Ltd
Tel: +27 31 701 5255
sales@tapflo.co.za

Turkey

Tapflo Makina Ltd
Tel: +90 216 467 33 11
sales@tapflo.com.tr

Ukraine

TOB Tapflo
Tel: +380 44 222 68 44
sales@tapflo.com.ua

United Kingdom

Tapflo (UK) Ltd
Tel: +44 2380 252325
sales@tapflopumps.co.uk

Tapflo AB

Filaregatan 4
S-442 34 Kungälv, Sweden

E-mail addresses:
Commercial questions
Orders
Tech support

Tel: **+46 303 63390**
Fax: **+46 303 19916**

sales@tapflo.com
order@tapflo.com
support@tapflo.com